

IMPROVING THE ENERGY CONSUMPTION OF AN INTENSIVE RECIRCULATING ACQUACULTURE SYSTEM USING A WATER-WATER TYPE HEAT PUMP

LAZA E.A.¹⁾, CABA I.L.¹⁾, COSTACHE M.²⁾, MATACHE A.³⁾, DUMITRU D.N.⁴⁾, SÎRBU F.D.⁵⁾,
ANDREI P.⁶⁾

¹⁾INMA Bucharest / Romania; ²⁾S.C.D.P. Nucet / Romania; ³⁾SAFE SMART SYSTEM Câmpina; ⁴⁾SC IOR SA Bucharest / Romania; ⁵⁾AGROMAD Crops SRL / Romania; ⁶⁾SC CALORIS SA Bucharest / Romania
E-mail: eveline_anda@yahoo.com

Keywords: *recirculating aquaculture system, energy consumption*

ABSTRACT

Aquaculture efficiency practiced in recirculating systems depends on a variety of factors, among which the most important is the energy consumed by the whole system. In order to assure a high degree of energy conservation, in a recirculating aquaculture system has to be maximized the recirculating water degree and has to be imposed the use of renewable energy sources for heating, respective for cooling the water within system as well as of hall. Maintenance of an appropriate climate in a recirculating aquaculture system involves high energy

consumption, determined by high water quantities which have to be heat or cool, as well as determined by maintaining water temperature and of breeding space.

An optimal solution for replacing conventional systems of heating/cooling and optimizing of energy consumption is the use of the heat pumps. In the present paper are presented experimental results performed with a heat pump of water-water type at different water replacing rates and two different water flows for demonstrating efficiency of a heat pump for improving energy consumption of a RAS.

INTRODUCTION

Worldwide, the aquaculture practiced in recirculating system presents a high interest especially valuable fish species.

Recirculating aquaculture systems in comparing with aquaculture practiced in traditional way in ponds present the advantage of land and water resources economy and allow fish growing in controlled environment conditions (Cristea V., et al., 2002; David E-A, et al. 2014).

This type of system allows water treatment by removal of residual solids, ammonia and nitrites oxidation, elimination of carbon dioxide, aeration and/or oxygenation and water disinfection, if necessary (Cristea V., et al., 2002; David E-A. et al. 2014).

The efficiency of aquaculture practiced within recirculating systems depends of a variety of factors, among which the most

important is the system energy consumption. To ensure a high degree of conservation of energy in a recirculating aquaculture system, the water recycling degree has to be maximized and has to be imposed the use of renewable energy resources for heating or cooling water or hall has to be imposed. In this purpose the optimal solution is to use water heating/cooling by a heating pump (Gavrilescu R., 2003, David E-A. et. al, 2014).

Maintaining an appropriate climate in a recirculating aquaculture system involves high energy consumption, determined by high water quantities which have to be heated or cooled.

An optimal solution for replacing conventional systems of heating, respective of cooling and optimizing of

energy consumption is using of the heat pumps.

The main heat pumps used in the present in function of the nature of the cool source are of air-water, water-water and soil-water types (David E-A, et al. 2014; Florescu A., et al. 1985; Gavrilesco R., 2003; Pop A. and David P., 2007).

By comparative analysis of different types of heat pump, depending on the nature of the source of the used energy, result the following data within table no.1. (Gavrilescu R., 2003; Pop A. and David P., 2007).

Table 1

Types of heat pumps according to the type of energy source used

Type/Characteristic	Air – Water	Water –Water	Soil – Water
Value COP	small	big	big
Variation COP Depending on the climate conditions	variable	constant	relatively constant
Installing costs	small	big	very big
Operating safety	small	big	big
Thermic power	small	very big	big
Possibility of passive cooling	no	yes	only models with vertical wells

In which COP is the coefficient of real performance and is defined as a ratio between the produced thermic energy and electric energy consumed for producing it.

The operation of heating / cooling water from the RAS heat pump type water - water is shown in the figure below. The system consists of five different circuits.

- A – primary circuit of groundwater extracted from the well, (cool source),
- B – circuit of refrigerant,
- C – intermediate circuit of warm or cold water,
- D – circuit of passive cooling,
- E – circuit of recirculating aquaculture system, RAS.

For carrying out the heat, the groundwater extracted from the well (1) by means of the submerged pump (2) reaches the evaporator of the heat pump (4), where it gives off heat of the refrigerant, which evaporates.

Groundwater which is initially at a temperature of 8 ÷ 10°C, while passing through the evaporator is cooled to approx. 5°C, to about 3 ÷ 5°C.

This water is reintroduced into the second well (drain well). Refrigerant, which has boiling temperature at -2°C, takes heat from the groundwater and

turns into vapor. The vapor are compressed in the compressor and go to a temperature of + 73.5°C, after which get the condenser, where by condensation give off heat (latent heat of evaporation) to the water from an intermediate circuit. The refrigerant returns to a liquid state and the cycle continues. The water heated in the intermediate circuit at 65 ÷ 68°C is introduced into the external heat exchanger (6), where it gives up heat to the water re-circulated from the basins of the fish growing.

The cooling process is carried out in a similar manner, only the water circuits of the heat pumps reverse. Water reaches the secondary circuit evaporator where the refrigerant gives off heat that vaporizes and groundwater takes heat from the refrigerant in the condenser (Răduleț R. et al., 1957-1966). The water cooling process is used only in exceptional cases (at very high temperatures). Usually it is used a so-called passive cooling water, which consists in introducing the groundwater directly into the external heat exchanger by passing of the heat pump. Thus the recycled water from the basins releases heat directly to the groundwater.

This operating mode is particularly advantageous because it consumes only electricity required for driving the

submersible pump (David E-A, et al., 2014; Florescu A. et al. 1985; Pop A. and David P., 2007; Pop A., 2007).

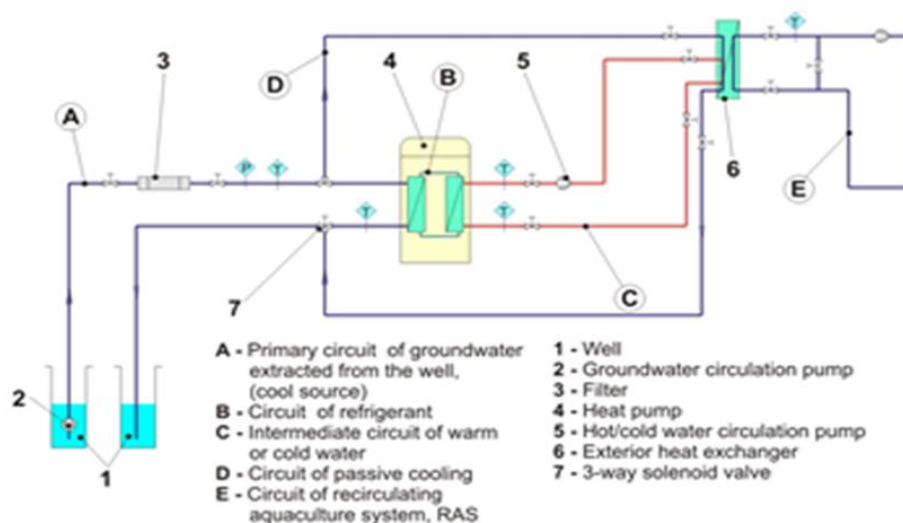

The functioning scheme of a heat pump for RAS

MATERIAL AND METHOD

The recirculating aquaculture system on which has been executed the experiments in order to determine the energy consumption using the heat pump was composed of: 9 basins for fish growing with a volume of 5.65 m³ water/basins, water supply systems and drainage, in and from the basins, a group of pumps, an UV sterilizing apparatus, biologic filter, installation of heating/cooling with heat pump, heat exchanger, aeration and oxygenation systems, continuous monitoring devices of the physical-chemical parameters of the water (probes for the determination of oxygen dissolved, temperature, nitrate and nitrite, pH, conductivity, and turbidity of the suspended solids, ammonium), control and automation installation and drilling for cleaning water.

For the *water heating* experiment, the storage basins was filled with water after which the valves of the basins have been open. The water volume contained in the system was:

$$V_T = n \times V_B + V_{BS} = 9 \times 5,65 + 21,2 \text{ m}^3 = 72,05 \text{ m}^3$$

where: V_T [m³] – total volume of water contained in the system; V_B [m³] – real volume of the tank used for growing; V_{BS} [m³] – real volume of the storage basin; n – number of the breeding basins;

Within calculation was neglected the water amount contained in the pipes as it is about 0.01% of the total volume of water. Since the drilling system for the fresh water supply is equipped with a pump of small capacity (for cca.7 m³/h), filling the entire system was performed in several steps, in total in 36 hours. Because of the operation duration, the temperature of the water in the system, t_1 , has come to ambient temperature t_a .

$$T_1 = t_a = 14^\circ\text{C}$$

It has been scheduled the operating temperature of the system to be:

$$T_2 = 20^\circ\text{C}$$

Was started the water circulation in the system with the circulation pumps. As water circulation through filters does not influence the thermal balance, in order to avoid water losses and useless energy consumption the basins evacuation system was directly connected to aspiration of recirculating pump.

Then, it was performed pump heat operation. It was chosen an operating regime which allows the water heating from the secondary circuit flow to 35°C. It has been found that after approximately 10 hours of operation, water within the system has reached the temperature $t_2 = 20^\circ\text{C}$.

For water heating within the system has been consumed a total amount of electrical current, $E_c = 99 \text{ kWh}$ [2,3,6].

Finally, we determined the performance coefficient of the heat pump:

$$\text{COP} = \frac{E_T}{E_c} = \frac{546.9}{99} = 5.52$$

The next stage of the experiment was to maintain the operating temperature of

the system at $T_s = 20^\circ\text{C}$, with different refresh rates of water. Thus, there were carried out refresh rates of the water system with 10 %/24 hours, 20 %/24 hours and 30 %/24 hours

Water replacement rate: 10 %/24 hours

The volume of the recirculating system is: $V_r = 9 \times 5.65 \approx 50 \text{ m}^3$

The amount of water for substitution is:

$$V_1 = 10\% \times 50 = 5 \text{ m}^3/24\text{h}$$

After replacing an amount of about 5m³, the water temperature in the basin reached 20°C at:

$$T_1 = 18^\circ\text{C}$$

RESULTS AND DISCUSSIONS

Measurements were carried out on a heat pump water-water type for heating and cooling regimes and the obtained results were filled in the tables below.

It has been calculated the thermal energy used to heat the water up to

temperature $t_2 = 20^\circ\text{C}$ and has been read the electricity consumption. The experiments were repeated for different rates of replacement of the water in the system. The obtained results are shown in table no. 2.

Table 2
COP results on the rate and amount of water replacement for heating the water in the system

Den. no.	Replacement rate [%/24 ore]	Water amount of replacement [m ³ /24 ore]	Temperature t_1 [°C]	Temperature t_2 [°C]	E_T [kWh]	E_c [kWh]	COP
1	10	5	18	20	51.99	9.65	5.39
2	20	10	16	20	87.24	16.04	5.44
3	30	15	15	20	128.12	23.60	5.43

Results an average performance coefficient:

$$\text{COP}_{\text{Medium}} = 5.42$$

The difference towards the theoretical COP is due to heat loss into the environment due on account of low degree of insulations.

Tests for *water cooling* were carried out when the ambient temperature was 18°C, water was heated until 25°C, after which the cooling cycle was start. Final cooling temperature was set at 20°C. After measurements have been obtained the following results filled in the table no. 3.

Table 3

Measured values for water cooling

Den. no.	t_a [°C]	t_1 [°C]	t_2 [°C]	E_c [kWh]	E_T [kWh]	EER
1	18	25	20	69.03	462.48	6.7
2	18	24	20	56.42	377.99	6.7
3	18	23	20	43.80	293.49	6.7
4	18	22	20	31.19	208.99	6.7

Where: t_a [°C] = room temperature;

T_1 [°C] = water temperature in the system at the start of test;

T_2 [°C] = water temperature in the system at the end of test;

E_c [kWh] = consumed electricity;

E_T [kWh] = thermal energy;

EER = cooling power efficiency is the ratio of consumed electric energy and generated cooling power.

Technology for fish growing in recirculating aquaculture system is a technology of high energy consumption.

Maintaining an appropriate environment within a recirculating aquaculture system

for fish growing supposes high energy consumption as a consequence of high water quantity which has to be heated or cooled, as well as through maintaining water temperature and air in the hall.

A significant share from production costs are represented by expenses with energy consumption for heating and cooling water within the basins. For this reason it is recommended to use the most efficient solutions for thermal energy producing, necessary for the system. In the table 4 are summarized the results from measurements made with a heat pump water-water type.

Table 4

Values obtained from measurements made on a heat pump type water-water for heating and cooling mode

Name of requirement	Temperature cool sources/Flow temperature	M.U.	Prescribed value	Measured (calculated) value
Heating mode				
Heating capacity	W10/W35	kW	54.4	53
Absorbed power	W10/W35	kW	9.9	9.8
Performance coefficient, COP	W10/W35	-	5.5	5.4
Absorbed current	W10/W35	A	18.8	18.6
Cooling mode				
Cooling capacity	W10/W18	kW	63.6	63.6
Absorbed power	W10/W18	kW	9.5	9.5
EER cooling energy efficiency	W10/W18	-	6.7	6.7
Absorbed current	W10/W18	A	16.5	16.5

CONCLUSIONS

The technology for fish growing in recirculating aquaculture system is a technology of high energy consumption.

The most efficient method from economic point of view for heating and cooling the water from RAS is to use heat pumps.

By using a heat pump water-water type with a COP = 5.4, 1kWh of thermal energy has been obtained approximately 5.4 times cheaper than that obtained by using electricity.

BIBLIOGRAPHY

1. **Cristea V., Grecu I. Ceapă C.** 2002– Engineering of recirculating aquaculture system, Ed. Didactical and Pedagogical R.A. Publishing, Bucharest, p.13-27;
2. **David E-A, Pop A., Andrei Sorin** - Theoretical considerations regarding improving energy consumption of a recirculating aquaculture system of superintensive fish growing, ISB INMA TEH' 2014, International Symposium, 30 october – 1 november Bucharest, ISSN 2344-4118.
3. **Florescu A. Duicu T., Burchiu N.** 1985 – Installations of heating pumps, Technical Publishing, Bucharest,
4. **Gavrilescu R. 2003** – Heating pumps, Matixrom Publishing, Bucharest;
5. **Pop A., David P. 2007**– Utilization of heat pumps for water heating/cooling in fish superintensive recirculating breeding systems., "INMATEH 2007-V c" no.23, I.N.M.A. Bucharest, Publishing, November 2007, ISSN 1583 – 1019, p. 209-214;
6. **Pop A. 2007** – Research and development of a technology of fish superintensive breeding within a recirculating system with optimization of technological parameters and assuring the sanitary-veterinary protection, PN II Programme 4 "Partnerships in Priority Areas" 2007 – 2013. Contract nr.51- 054 / 14.09.2007, p. 95-114;
7. **Răduleț R. et alt.,** 1957-1966– Romanian Technical Lexicon, Technical Publishing, Bucharest.