

INNOVATIVE SOLUTIONS FOR VERTICAL TRANSPORTATION OF GRAIN SEEDS AND TECHNICAL PLANTS

**BUNDUCHI G.¹⁾, GĂGEANU P.¹⁾, PĂUN A.¹⁾, GĂGEANU I.¹⁾, ZAICA AL.¹⁾,
EPURE M.¹⁾, UNGUREANU N.²⁾, SÎRBU F.D.³⁾**

¹⁾INMA Bucharest / Romania; ²⁾U.P. Bucharest / Romania; ³⁾AGROMAD Crops SRL / Romania
E-mail: georgebund@yahoo.com

Key words: *elevator, transport, interphasic, seeds, grains, technical plants, powdery*

ABSTRACT

In order to provide a technical and material basis which allows the best possible preparation of grain seeds and technical plants before being processed, consumed or stored, at the level of the European norms in the field, including compliance with the ecological requirements, a technical equipment is needed to respond all these

requirements. The paper presents a belt elevator, with buckets, which is an integral part of the technological flows in silos, seed conditioning plants, FNCs, beer factories, oil factories and is intended for the vertical transportation of granular and powdery products, hence an effective and efficient solution in this field.

INTRODUCTION

Agriculture is one of the oldest forms of human activity and one of the important fields of activity of the Romanian population. It plays an important role in people's lives because it is a way of survival.

An important role has the development of the appropriate conditions for taking over, processing, storing and capitalizing on the obtained agricultural products. Facing with a tendency towards more and more efficient plants for grain processing, and the technology for interphasic transport has to meet growing demands in this field.

An intense activity was carried out in order to develop specific equipment of the technological lines from grain silos and in the milling complexes destined for the

interphasic transport, and to find new solutions to ensure on the one hand the fulfillment of the agrotechnical requirements by the correct handling of the seeds, and on the other hand, of the exploitation requirements, aiming at reducing material and energy, while ensuring the safety in exploitation.

The simple elevator with conveyor belt and buckets is a world-class performance machine in the field, designed for vertically transporting both grain and technical plants seed, and powdery products.

The equipment is part of an action to promote the most modern technologies and equipment in the milling industry, based on the obtaining of high quality products or qualitative seeds needed for processing in the food industry.

MATERIAL AND METHOD

The development of the elevator with conveyor belt and buckets (Fig.1) required the adoption of modern constructive solutions that lead to superior technical - functional

performances. The elevator with conveyor belt and buckets consists of the following main components: elevator head, elevator foot, drive group, normal section, viewing section, end section, door section, conveyor

belt with buckets, unisens device, head suction, foot suction, housing (Figure 2).



Fig.1 - Elevator with conveyor belt and buckets

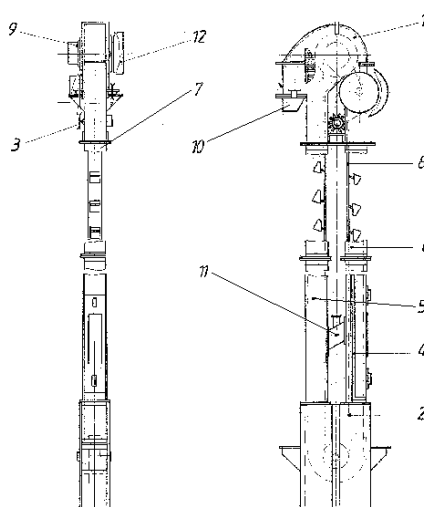

Fig.2 - Sketch of the machine

1. Elevator head; 2. Elevator foot; 3. Drive group; 4. Normal section; 5. Viewing section; 6. Door section; 7. End section; 8. Conveyor belt with buckets; 9. Unisens device; 10. Head suction; 11. Foot suction; 12. Housing

RESULTS AND DISCUSSIONS

The product to be transported is brought to the foot of the elevator through the feeding hopper, and then is taken up by the buckets over the upper drum and discharged through the discharge hopper into other machinery parts of the technological line.

The movement of the bucket belt is provided by the drive group fitted with a gearmotor, periflex coupling, or gearmotor and screw coupling.

From the output shaft of the gearmotor, through the periflex coupling or by bolts, the movement is transmitted to the shaft of the upper drum. The conveyor belt with buckets is spread over the two drums and stretched, taking over

the movement through the friction that appears between the wrapper of the driven upper drum and the band that winds it. In this form, the conveyor belt with buckets is driven in continuous movement, transporting the loaded buckets to the upper drum and the discharged buckets to the lower drum.

In order to increase the safety in exploitation, the elevator is provided with a unisens device, which prevents possible accidents, in case of accidental stopping of the belt. When the elevator stops accidentally while loaded, with the upward branch of the belt with product-loaded buckets, its reverse movement under the influence of gravity is blocked by the

unisens device. Thus is avoided the unloading of the buckets in the elevator foot, clogging of the elevator, and in some cases even the stripping of the buckets from the belt or belt breaking.

In order to ensure the suction of the product to be processed, the machine was designed with suction at the elevator head and at the elevator foot, and in order to easily adjust the length of the belt, in the elevator foot was provided a system for belt straightening and adjustment on the drums. To avoid seeds crushing, a grid-

type drum was designed between the band and the lower drum wrap, giving the seeds the possibility to slide and fall at the base of the foot, from where they can be feed again

The elevator with conveyor belt and buckets is a compact and enclosed design, with the possibility of connection to the suction system in the technological flow at both its head and foot, which protects the environment from the above mentioned noxes.

Technical - functional characteristics

- Transport capacity:
 - for grains, t/h: 20
 - for flour, kg/h: 12
- Breaking index, %: .0,5
- Air flow to aspiration m³/min: 30 - 40
- Distance between axes H, m: 5 –40
- Speed of the belt with buckets, m/s: 2;
- Installed power, kW, depending on H: 1,1 – 5,5
- Overall dimensions:

- Length, mm: 2.400
- Width, mm: 2.250
- Height, mm: 6.500 – 41.500
- Bucket characteristics:
 - width, mm: 180
 - bucket opening, mm: 130
- Belt characteristics:
 - width, mm: 200
 - bucket pitch, mm: 325
- Size of tubing sections, mm: 244x244x2000.

Table 1

Parameters obtained in operation

No.	Requirement	M.U.	Provided in the execution project	Achieved in trials
1	Overall dimensions: - maximum lenght - width - height	mm mm mm	2400 2250 6500...41500	2400 2250 7525
2	Distance between axes	mm	5000...40000	6375
3	Drums diameter	mm	500	500
4	Frequency of drum rotation	mm	76	76
5	Belt width	mm	200	200
6	Speed of the belt with buckets	m/s	2	2
7	Bucket pitch	mm	325	325
8	Bucket width	mm	180	180
9	Fly (opening) of the bucket	mm	130	130
10	Power of electric motor	kW	1,1...5,5	2,2
11	Frequency of rotation for the electric motor	rot/min	945	944
12	Size of tubing	mm	244x244x2000	244x244x2000

CONCLUSIONS

Based on the data obtained (shown in Table 1) when testing the elevator with belt and buckets, it was confirmed the opportunity of the chosen constructive

solutions and the technological equipment, conditions that allowed the execution of a very efficient machine with performances at the level of the latest

achievements, ensuring the reduction of specific energy consumption, maintenance and exploitation per ton of processed product.

The following were also found:

-the constructive design is modern, fully enclosed, ensuring the possibility of connection to the suction installation in the technological flow, which protects the environment against emissions;
-the technological adjustments are simple to achieve, providing stability over time;

-the construction allows for the reduction of specific energy consumption, together with easy maintenance and operation

-the adjustments can be made easily, allowing quick service for daily and periodic maintenance;

-the constructive solution leads to protecting the environment by preventing dust emissions at the workplace and in the atmosphere, the equipment being provided with couplings at the dusting installations of the user units.

BIBLIOGRAPHY

1. **Banu C.**, 2002 - *Manual of the Food Industry Engineer*, Volume 1, Technical Publishing.

2. **Brăcăcescu C.**, 2012 - *Optimization of the primary processing processes of grain seed crops*, "Terra Nostra" Publishing, ISBN 978-606-623-003-2, Iași.

3. **Brăcăcescu C., Pirnă I., Sorică C., Popescu S.**, 2012 - *Researches on the influence of functional parameters of combined installations of impurities separation from the cereal seeds on the quality indicators of the cleaning process*, Proceedings of 5th international mechanical engineering forum, pag. 223-236, Praga, ISBN 978-80-213-2291-2 1.

4. **Brătucu Gh., Căpățînă I., Păunescu C.G.**, 2009 - *Manufacture of technical equipment for agriculture and food*

industry, University Transilvania of Brașov Publishing.

5. **Căsândroiu T., David L.**, 1994 – *Machinery for primary processing and storage of agricultural products*, Guidance for laboratory work, University Politehnica of Bucharest.

6. **Costin I.**, 1988 - *Book of the Miller*, Technical Publishing, Bucharest.

7. **Gageanu P.**, 2008 - *Modern technical equipment for the preparation of grain seeds for sowing*, Magazine of Agriculture mechanization, New AGRIS Publishing – Agricultural magazines - ISSN 1011-7296.

8. **Leonte M.**, 2001 - *Technologies and equipment in the milling industry*, Millenium Publishing, Piatra – Neamț, 2001.