

ASPECTS REGARDING BIOMASS FROM ENERGETIC PLANTS (ENERGETIC WILLOW – SALIX MINIMALIS) GRINDING PROCESS FOR PELLETIZATION

CHIȚOIU M.¹⁾, MOICEANU G.¹⁾, VOICU GH.¹⁾, PARASCHIV G.¹⁾, VLĂDUȚ V.²⁾,
GĂGEANU I.²⁾,

¹⁾U.P. Bucharest / Romania; ²⁾INMA Bucharest;
E-mail: chitoiu_mihai@yahoo.com

Keywords: hammer mill, energetic willow, chipping, energy consumption

ABSTRACT

Using energetic plants like energetic willow in the process of developing renewable energy processes, is under heavy research and development by scientists. Energetic crops are subjected to a technological process mainly for easy maneuverability purposes. An important processing phase is energetic plant grinding. The present paper describes researches regarding the grinding process of ha hammer mill using energetic willow as feeding material. 4 types of hammers and 5 grinding speeds were used. Starting from this data the necessary energy consumption for a 5 mm sieve was calculated.

INTRODUCTION

Different types of renewable resources are being studied and researched by scientists, in order to gradually end fossil fuel dependency, which, according to specific studies, are the main cause of greenhouse effect. Another problem in constantly using fossil fuels is that this type of resource is limited, but the consumption rises annually, due to the increasing number of vehicles and hyped industrialization of developing countries.

The need for renewable energy sources that can take the pressure off using fossil fuels is clear, and implementing systems that gradually end petrol use has become a priority.

Although forestry waste offers a considerable source of biomass, in order to protect forest spaces, it has been approved to search and develop other sources of biomass [3].

A source that has benefited from proper studies and researches was the energetic willow, used as a renewable biomass source for different applications: pelletizing, briquetting, combined with different materials for biogas yielding, etc.

There is a large variety of energetic willow species spread on Earth, but for renewable energy applications, *Salix viminalis* is one of the most researched, due to its high growth rate and high annual quantity of biomass levels.

Being a perennial species, the energetic willow is a separation from the typical crop patterns, usually based on annual crops, harvested in rotation, to ensure a fertile soil and healthy crops. Energetic willow can be harvested for the first 4 years after plantation, usually by branch cutting, and then harvested every three years [1].

The main strong points of energetic willow used as a biomass source are: large quantities of biomass, environmental friendly, high energetic efficiency, possibility of plantation in areas where other crops aren't growing. Weak points are: high cost for initial plantation, high costs for transportation, and high humidity content.

The main problem of these biomass sources is maneuverability, so, in order to easily manipulate and prepare the material for pelletizing process, energetic willow is grinded with the help of specific equipment. The most popular equipment is the hammer mill, which is the subject of numerous researches with the purpose of reducing energy consumptions, grinding time, and other researches regarding the physical-mechanical properties of energetic willow in relation to the equipment.

Also, the humidity content from biomass is a factor which significantly influences grinding energy consumption, especially when targeting small granulations.

One observation that stands out of most researches is that the energy consumption rises with using smaller orifice sieves, for obtaining finer grain of biomass [2].

In the present paper, researches were realized for energetic consumption, in relation to using 4 types of hammers, 5 different speed, and using a 7mm orifice sieve, in order to choose the optimum recipe between energy consumption and the quality of grinded material.

These types of studies are absolutely necessary for implementing different modifications for the grinding equipment, in order to reduce energy costs and maintenance costs.

MATERIAL AND METHOD

Experimental researches realized in order to achieve the paper's objectives took place at INMA – Bucharest, using a hammer mill type TCU. This mill can be used for milling different biomass types. In this case biomass was collected from the institute's terrain and then subjected to the grinding process. Energetic willow was previously subjected to a gross grinding process. The resulted material was manually placed in the hammer mill.

Energetic willow grinding was achieved by hitting and shearing the material between hammers located on the hammers disk and the counter knives. The chopped material is then collected by the ventilator into the cyclone that has two bag opening possibilities, being evacuated in either one and collected for further use. Important characteristics of the mill that need to be mentioned are: milling capacity of 900m³/h, electric motor power 22kW, electric motor speed 2940 rot/min, possibility to change the position of the collecting bag according to the necessities, interchangeable grinder sieve with different hole sizes.



Fig. 1 - Vegetal waste mill (hammer mill) – MC 22

Experimental researches were realized using four types of hammers and a 7mm orifice sieve. Also, another parameter which varied during testing was the rotor speed, with values of 50Hz, 47.5 Hz, 45 Hz, 42.5 Hz, respectively 40 Hz.

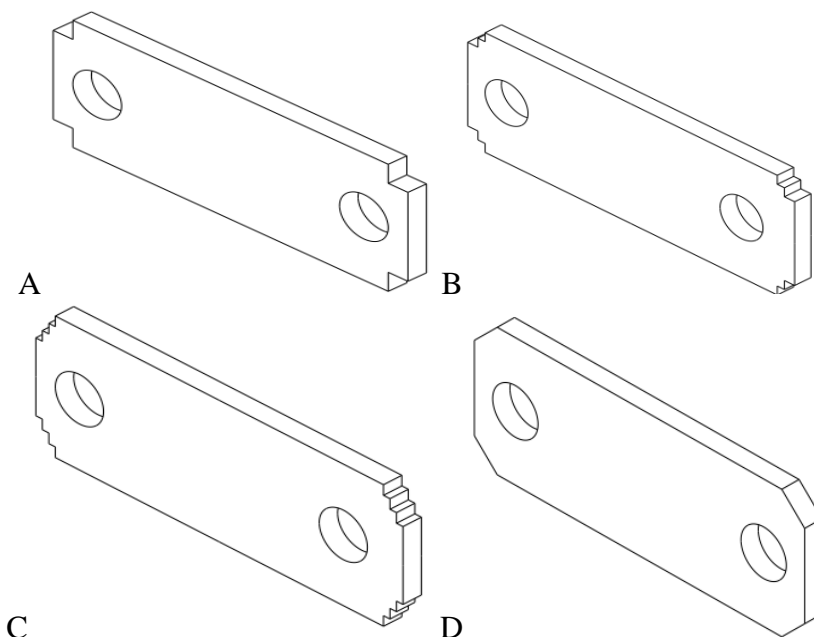

Fig.2 Four types of hammer used for testing

A – one step hammer; B – two step hammer; C- three step hammer; D – triangle hammer

In this paper, experimental data was interpreted based on literature which presents similar test done on different biomass types.

RESULTS AND DISCUSSIONS

Table 1 presents the results of the experimental tests resulted from grinding energetic willow. Also, the results are shown in figure 3.

Table 1

Remaining quantity of material on the sieve

Probe no.	Speed (Hz)	Quantity of material on the sieve (g)											
		Particles smaller than 4 mm				Particles between 4 and 7 mm				Particles bigger than 7 mm			
		A	B	C	D	A	B	C	D	A	B	C	D
1	50	0.73	0.93	1.56	1.19	2.5	2.72	2.36	2.16	1.73	1.31	1.04	1.61
2	47,5	1.19	1.44	1.19	0.91	2.56	2.47	2.16	2.08	1.21	1.05	1.63	1.96
3	45	1.13	1.37	1.29	1.13	2.44	2.42	2.22	1.89	1.39	1.17	1.43	1.97
4	42,5	1.00	0.99	1.18	1.09	2.64	2.68	2.18	2.03	1.32	1.19	1.60	1.87
5	40	1.84	0.99	0.96	1.55	2.02	2.49	2.39	1.97	1.09	1.48	1.60	1.44

From what we can see in table 1 and from the resulted variation curves, most material particles were recorded for 4 and 7 mm fractions.

Also, analyzing particle distribution according to the hammer type we can conclude that the largest quantity was recorded for the triangle type hammer D and larger dimensions of 7 mm.

Through polynomial regression analysis of the second degree we can see, that for smaller 4mm particles, a correlation coefficient of 0,5741 for type B hammer (with two steppes), and for the the D type hammer (triangle) the correlation coefficient was 0,9429.

Using the same type of second degree polynomial regression analysis for analyzing particles between 4 and 7 mm, a correlation coefficient larer than 0,68 was obtained for all

4 types of hammers, the largest being recorded for the type C hammer (with three steppes).

The largest obtained correlation coefficient for particles larger than 7mm was 0.98 for type D hammer (triangle).

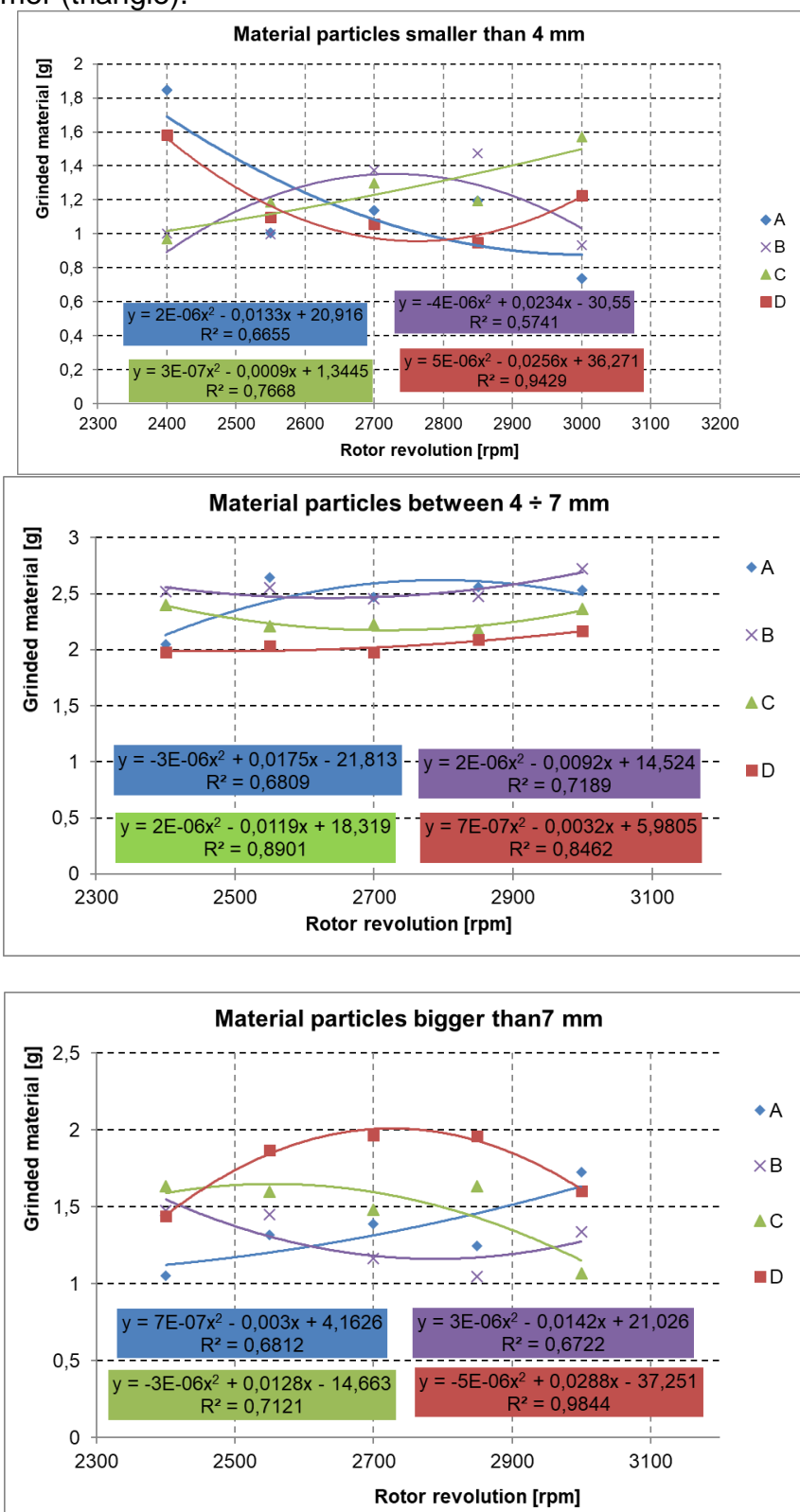

Fig. 3. Variation of the material particles remaining on the sieve

Considering the fact that the hammer used during experimental testing and the rotor speed are input parameters, output parameters like grinding degree and consumed energy

during grinding process were analyzed. Thus, for a proper interpretation of the results, experimental data were processed with the help of Microsoft Excel, which produced graphs from figure 4.

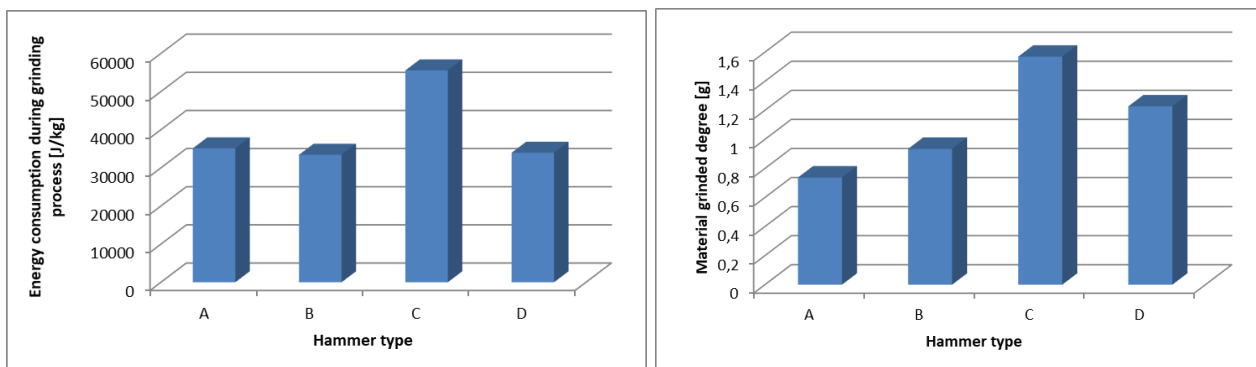

Fig. 4. Variation of energetic willow consumed energy and degree of grinding for 50 Hz speed (3000rpm)

Through a comparison of the two resulted parameters for 3000 rpm speed we can mention an optimum energy consumption with an average grinding degree for the type B hammer. Also, we can observe in figure 4 that the highest energy consumption was recorded for type C hammer.

For 2850 rpm speed we can see a high energy consumption for type A hammer at an average grinding degree. The lowest grinding degree was recorded for type D hammer with a low energy consumption during the grinding process. Optimum grinding in this case was recorded for the type C hammer.

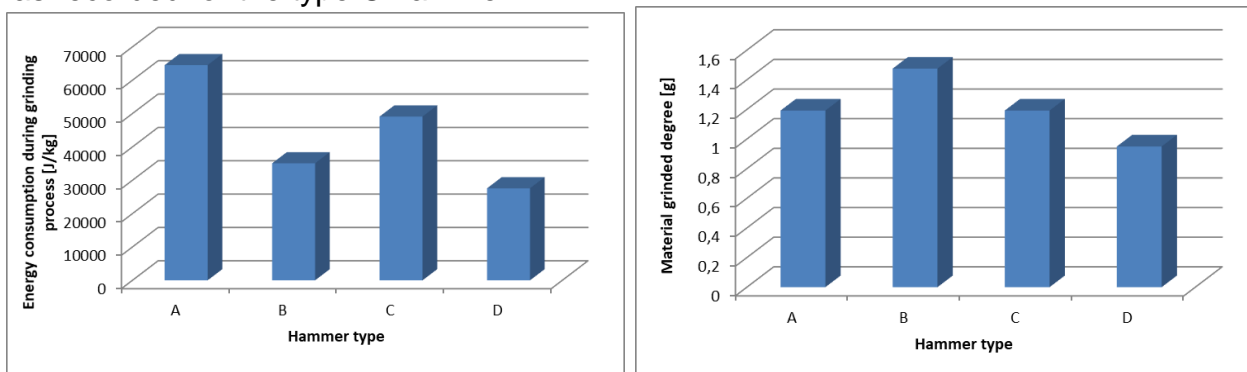

Fig. 5. Variation of the energetic willow consumed energy and the grinding degree for de 47,5 Hz rotor speed (2850 rpm)

By analyzing the grinding degree at 2700rpm we can see a high energy consumption for all hammer type

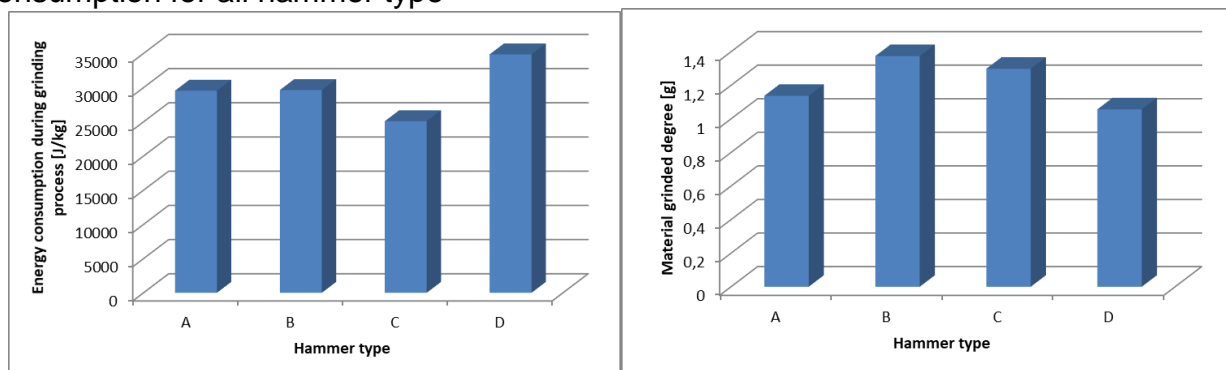

Fig.6. Variation of energetic willow consumed energy and grinding degree for 45 Hz rotor speed (2700 rpm)

By parameter analysis at 2550 rpm speed we can mention the fact that although the highest grinding degree was recorded for the type C hammer, the energy consumption was high, From figure 7 we can say that the optimum figure for this speed is given by the type D hammer which recorded an optimum energy consumption for an adequate grinding degree for the next phase of the energetic willow technological process.

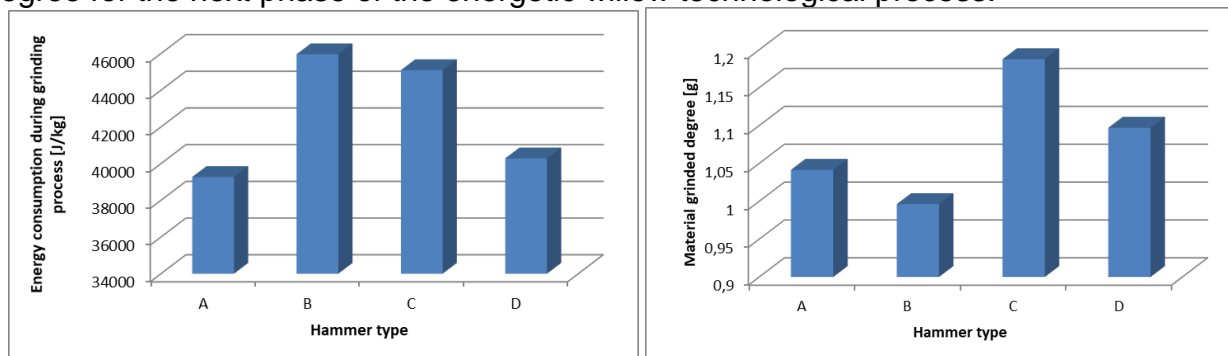

Fig. 7. Variation of energetic willow consumed energy and grinding degree for 42,5 Hz rotor speed (2550 rpm)

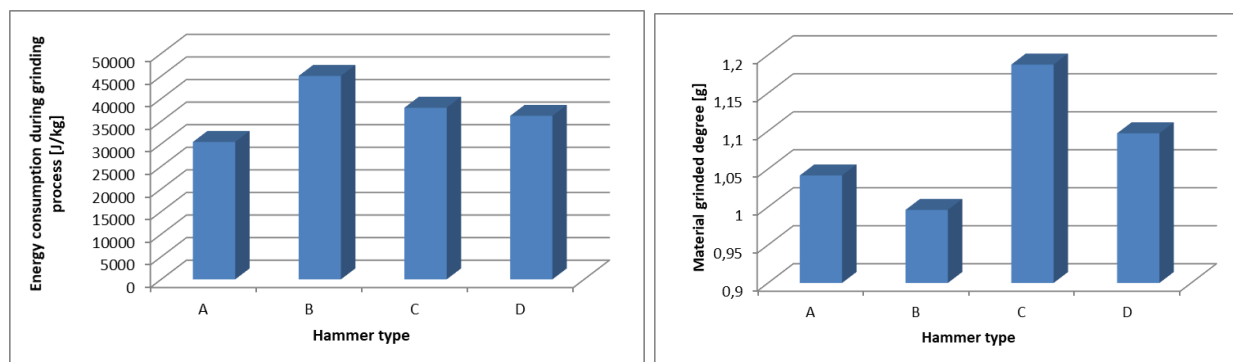

Fig. 8. Variation of energetic willow consumed energy and grinding degree for 40 Hz rotor speed (2400 rpm)

Comparative analysis for output parameters at 2400 rpm rotor speed, outline an optimum figure for type D hammer. A significant difference between parameters can be observed for the type B hammer, where, although the grinding degree was low, a high energy consumption was recorded.

CONCLUSIONS

Knowing technological requirements for biomass processing phases in renewable energy production and the requirements from a finite product point of view, are necessary, in order for the material to correspond to each specific phase. Thus, particle dimension resulted following the grinding process contribute to the quality of the finished product (briquettes, pellets), The mixture of material of different dimensions ensures a better link of material during the pelletizing phase.

Through the presented experimental research, in this paper we can see exactly that link. Also, we can conclude which type of hammer is regarded as optimum for a certain type of rotor speed of the hammer mill:

- For 3000 rpm rotor speed optimum hammer was type B
- For 2850 rpm rotor speed optimum hammer was type C
- For 2700 rpm rotor speed optimum hammer was type C
- For 2550 rpm rotor speed optimum hammer was type D
- For 2400 rpm rotor speed optimum hammer was type D

ACKNOWLEDGEMENT

This work was partially supported by the strategic grant POSDRU/159/1.5/S/137070 (2014) of the Ministry of National Education, Romania, co-financed by the European Social Fund – Investing in People, within the Sectoral Operational Programme Human Resources Development 2007-2013

BIBLIOGRAPHY

1. **Finch JW, Karp A, McCabe DPM, Nixon S, Riche AB, Whitmore AP.** *Miscanthus, short-rotation coppice and the historic environment.* English Heritage Report; 2009;
2. **Himmel M, Tucker M, Baker J.** *Comminution of biomass: hammer and knife mills.* Biotechnology Bioengineering Symposium. 1985;15(15):39–58;
3. **Rosso L., Facciotto G., Bergante S., Vietto L., Nervo G.** *Selection and testing of Populus alba and Salix spp. as bioenergy feedstock: preliminary results.* Appl Energy. 2013;102:87–92.