

## STUDY ON THE CONVERSION OF A CONVENTIONAL TRACTOR INTO AN ELECTRIC TRACTOR

**GRIGORE I.<sup>1)</sup>, CRISTEA M.<sup>1)</sup>, MATACHE M.<sup>1)</sup>, SORICĂ C.<sup>1)</sup>, GRIGORE A.I.<sup>1)</sup>, VLADUȚOIU L.<sup>1)</sup>, SORICĂ E.<sup>1)</sup>, DUMITRU I.<sup>1)</sup>, PETRE A.A.<sup>1)</sup>, CRISTEA R.D.<sup>2)</sup>**

*1) INMA Bucharest;*

*2) University Polytechnic Bucharest, Faculty of Biotechnical Systems Engineering / Romania  
Tel: 0762432744; E-mail: ionica\_grigore2001@gmail.com*

**Keywords:** *electric tractor, pollution, noise, human health*

### ABSTRACT

The paper presents the study on how a classic tractor with internal combustion engine can be modified so that it is powered by a battery-powered electric motor. The article presents equipment and components with which a tractor can be modified so that it can run on electricity. In general, an electric tractor consists of the chassis from which the heat engine, electric motor, battery, control and configuration equipment, software used and communication equipment, of the electronic systems on board the tractor are removed.

### INTRODUCTION:

For the agricultural work the tractor is an indispensable vehicle. Since the advent of the tractor, the tractor has undergone numerous transformations, from steam-powered tractors to those with internal combustion engines from those that could only tow to the present being capable of having attached a multitude of machines that can be used not only in agriculture but also in many other industries. The more the need for food increases, the more agriculture develops, which through different technologies manages to increase the yield of each hectare of land. One of the directions in which agriculture is developing is the increase of the tractor fleet, which has led to and continues to increase the level of pollution in both air and soil.

Policy makers have recognized quite recently, although environmental specialists have taken numerous actions aimed at drawing attention to the high levels of pollution existing in the atmosphere or soil, that it is necessary to develop stricter rules with applicability

also in the field of agriculture on environmental protection.

Developers and manufacturers of specialized tractor engines have implemented many technologies that result in pollution reduction, but even with these technologies pollution has not decreased significantly. As many aspects of the replacement of thermal engines have been studied, from experiments with low-power tractors to those of high power such as the electric tractor developed by John Deere which has a power of 500kW, but there are also simulations within smaller firms that also develop electric tractors or concepts (Troncon D., Alberti L., 2020).

The easiest way to eliminate pollution caused by the use of fossil fuels is to replace the internal combustion engine with an electric one. This can be done, in theory, on any existing tractor chassis but it is recommended to use a tractor chassis equipped with a small to

medium-sized thermal motor, e.g. engines with power from 15 to 50 horsepower. For these types of chassis there is a wide range of electric motors at relatively low prices.

This article will show some of the equipment necessary to be able to make an electrically operated tractor by replacing the engine to an internal combustion engine tractor.

The elements to be included in the composition of an electric tractor shall be chosen according to the energy requirements for that tractor to carry out in optimal conditions the work for which it was designed.

The design of the actuator parameters, transmission, power battery and other main components of traction provides a theoretical basis for further research and the development of other electrical tractor actuators (Xiaofoei Zhang, 2017).

Conditions to be met by an electric tractor, generally a tractor of general use of low power, i.e. reduced working speed, transport of materials or scrap, sowing, cultivation and harvesting. It can also be used for ploughing but on small surfaces.

This type of tractor is best for use in enclosed spaces or in soiled environments to be protected.

Depending on the working conditions, the output power of the electric tractor is transmitted mainly in two directions, the first is to the driving wheels and the second is to the power outlet intended for towed machinery (PTO).

## MATERIAL AND METHOD

The engine is the tractor's energy source. In most cases it's a thermal motor. It converts the heat resulting from the combustion of fuel into mechanical energy, necessary for the movement of the tractor and the operation of the

machines in the aggregate.

Currently, the vehicle actuator system consists mainly of the engine, engine deck assembly and wheels. Replacing the thermal motor with an electric one benefits the environment as well as long-term savings. [6]



**Fig 1 Examples of electric vehicle engines [7,8,9]**

The electric tractor actuator system is similar to the car drive system, in fact it uses almost all the components that are also used in the automotive industry. This leads to a reduction in the cost of designing and converting a classic tractor into an electric, environmentally friendly one. The existing technology on electric vehicles has matured, and research on new batteries, which will have as little charging times and maximum battery life as possible, is advanced.

Figure 2 presents the block scheme of the electrical system which highlights how an electric vehicle works at the theoretical level.

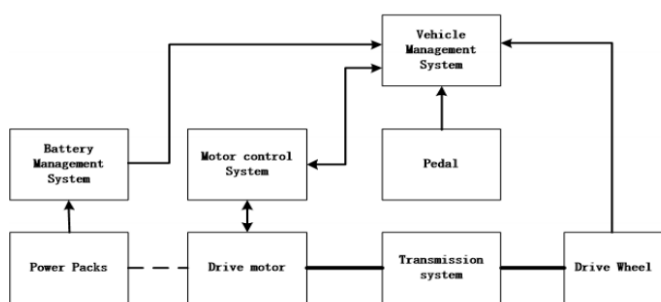

**Fig. 2 Tractor electric circuit block scheme ( Xiaofei Z., 2017)**

The main components of an electric propulsion system, the Vehicle Management System and Motor Control System, which is responsible for the currents and voltages with which the engine is powered, the accelerator pedal is the one that sends the engine start or stop signal to the controller, the battery management (BMS, Battery Management System) is components that keeps the battery within the parameters , the battery (Power Packs) is the power generator in the system, the engine (Drive Motor) is responsible for converting electricity into mechanical energy, this is done with the transmission system and further the energy reaches the running system (Drive Wheel).

Basically when the accelerator pedal is pressed the engine controller supplies the engine with electricity depending on the race of the accelerator pedal but also on how it has been configured to transfer power to the engine. With the help of a PC and dedicated software, you can determine the energy control strategy, from powering the battery from the power grid to the mode of energy regeneration to braking. Battery management is done by BMS but it is always in touch with all other components of the system using the CAN (Controller Area Network) so that both charging and unloading the battery

comply with the limits imposed by the manufacturer (Francesco M., Aurelio S).

Batteries used in electric vehicles can be virtually anything, i.e. from those with lead, NiMH, Li-ion, LiPo, LiFePo4 and many others. In general it is recommended to use the battery with LiFePo4 because it has a very good performance price ratio. Usually these batteries have quite high energy storage capacity, about 170mA h/g, does not contain expensive elements such as cobalt or nickel.

Due to the voltage that a single cell generates, 3.2V being the rated voltage, battery batteries can be built from 12V to 250V easily, depending on the requirements imposed by the project. There is research using computer simulations where concepts and theories on new technologies for battery development can be developed and verified (Lagnelov O.et al, 2020).

The required requirement is that the battery satisfies the condition that the energy charged is greater than the energy consumed.

$$W = P * T \quad (1)$$

Where: W is the energy needed  
P is the nominal power;  
T is time;

Determine the total capacity of the battery according to the total theoretical energy consumed by the power pack:

$$E_n = \frac{1000 * W}{U} \quad (2)$$

Where : En is the total required battery power

U is the rated voltage of the battery  
Examples of batteries:

a



b





c

**Fig. 3 a) Battery with lead rated voltage 12V, current 55A, b) LiFePO4 battery, rated voltage 3.2V current 100A c) Li-ion battery, rated voltage 3.6V, current from 2.2A [10,11]**

The Battery Management System (BMS) is the battery that ensures that the battery has as much operating time as possible by managing the charging parameters, controlling the discharge current and the temperature of each cell belonging to the battery.

Some of the widely used BMSs are those produced by Orion, EMUS, STMicroelectronics, Texas Instruments or others.

There are battery solutions that are built together with the BMS in the same box resulting in virtually a compact component that can be used as such in different configurations. Thus built there is the certainty that the batteries have been well checked, the BMS is configured correctly and all battery monitoring sensors are calibrated.



**Fig. 4 Battery voltage sensor [12]**

When battery control, the exact BMS model must also be taken into account, as in many situations modules with specific sensors (e.g. Cell Modules) must also be fitted.



a



b

**Fig. 5 (a) BMS produced by Orion b) BMS produced by STMicroelectronics [13,14]**



a



b

**Fig. 6 (a) BMS produced by Texas Instruments b) BMS produced by EMUS [15,16]**

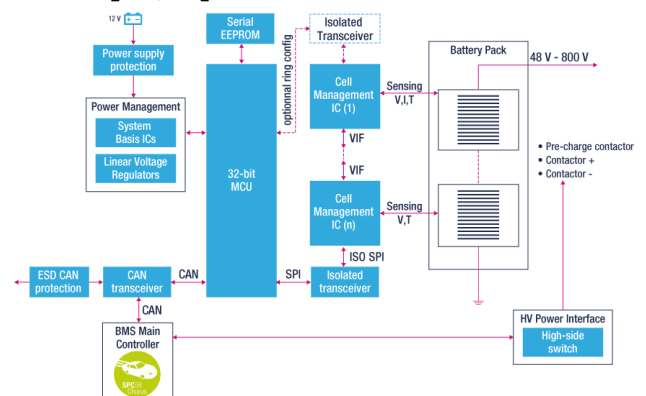
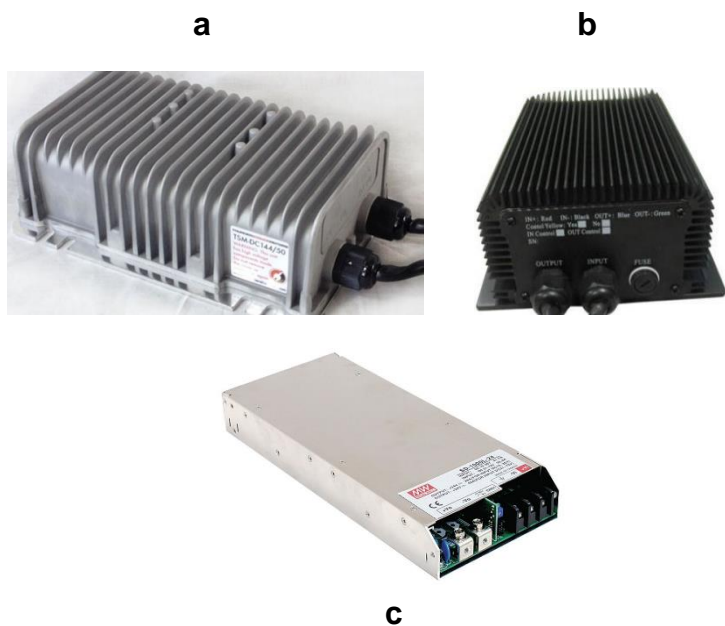

**Fig. 7 Scheme of principle of a BMS[17]**



## RESULTS AND DISCUSSIONS

The power control delivered to the engine shall be carried out by means of the engine controller receiving a signal from the accelerator pedal. Depending on the level at which the pedal is pressed proportionally the controller sends the current to the engine. The functions managed by the controller in general are the checking of engine temperature, the number of its rotations, the physical position of the rotor (to increase efficiency), real-time communication with subsystems in the system and other user-defined functions. There are different types of controllers that differ relatively little between them. Here are some examples:

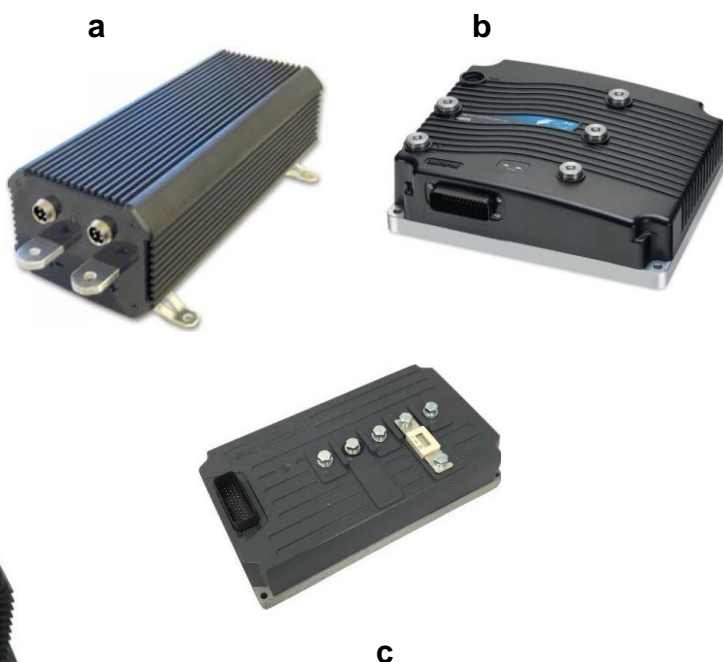

**Fig. 8 a) Controller ZEVA MC1000C (b) Controller SEVCON GEN4 c) Controller Curtis 1239e [18,19,20]**

For the system to work, in some configurations, there must be a 12V power source. This source may be another battery, different from that providing power for the engine, or a DC/DC converter capable of supplying in the 12V power branch so as to cover all existing consumers on the tractor but also

those who can connect when machinery is added to the tractor.

The solution with a 12V car battery is the cheapest and handy but needs a separate charger, also this battery also needs maintenance at different intervals. Different models can be used for converters, choose the model that meets the power conditions required by the project. Here are some examples of converters.



**Fig. 9 TSM DC/DC 96V Converter at 12V maximum 600W b) Kelly 96V Converter at 12V maximum 300W c) MEAN WELL 144V converter at 12V maximum 1000W [21,22,23]**

Battery charging is done with specialized chargers that have power at 1kW up to 10kW or more. 3.3 to 6 kW chargers are usually used, which can be supplied from the 110V, 220V or 380V network

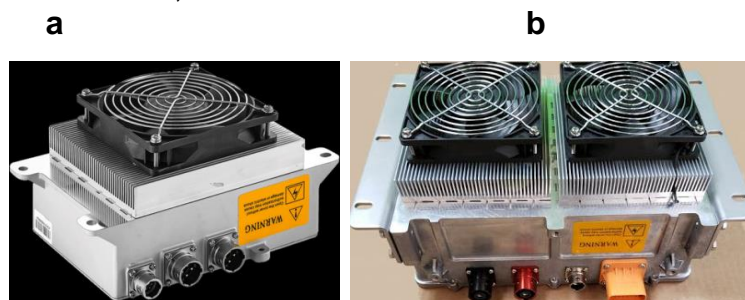

**Fig. 10 a) Charger TC 3.3 kW b) Charger TC 6.6 kW [24,25]**

The charger connects to the network using direct cable or specialized adapters, also called Charge Station.



**Fig. 11 Clipper Creek Level 2 Charging Station [26]**

All of these components shown above connect to each other in order to communicate between the different units or to connect with certain sensors, this implies the existence of a wiring which is specific to each type of tractor. The cabling has at least two large circuits, one of low voltage, one of 12 V and one of high voltage, the one of more than 48 V which is the power circuit.

These circuits must be made in such a way as to eliminate all hazards that may occur when working with medium or high power. Another aspect to be taken into account is the physical size of the cables, to be as short as possible, to have the section necessary to support the current that has been calculated, the communication cables to be shielded and made in accordance with the requirements of the protocol used.

It is recommended to use cables of the highest quality and if possible as flexible as possible. The design and implementation of the communication network must be carried out with great precision as interruptions or delays to the data flow may occur that may have negative effects (Mengnan, L., et al. 2020).

## **CONCLUSIONS:**

Thanks to efforts by institutions, organisations or NGOs worldwide to reduce pollution. the occurrence of any environmentally friendly machinery or

vehicle is a plus in reducing pollution. Converting the heat-powered tractor into an electric one, although it is a relatively major investment to begin with, is practically a source of long-term cost reduction, as it can be much more reliable than a heat-powered tractor, low energy consumption, does not pollute air or soil.

Research in the field of electric vehicles is advanced in all fields from automotive to aerospace, which shows us the interest that exists in eliminating pollution at a level never before seen worldwide. In general, the conversion of a thermal-powered tractor into an electric one can be done by small farmers up to large developers of agricultural equipment. The completion of such a project does not require a high level of knowledge in the field of mechanics or electronics because component manufacturers provide documentation and technical support at professional level.

The global trend is to replace all vehicles or machines that pollute the environment. As a result of the production and sale of motors, batteries and the rest of equipment for electric vehicles, and one of the effects of this is visible is the cheapness of these products.

The advantages of an electric tractor are obvious, do not pollute the air, much less noise, cheap maintenance, cheap fuel (electricity) and much more. The emergence of electric tractors is only just beginning, but looking into the future they will be much more present on farms all over the world.

## **ACKNOWLEDGEMENT:**

This work was supported by a grant of the Ministry of Education and Research on the Programme 1 – Development of the national research-development system, subprogramme 1.2 – Institutional performance – Projects for financing excellence in RDI, contract no. 16 PFE

## BIBLIOGRAPHY:

1. Francesco M., Aurelio S., 2020. Analysis of a Parallel Hybrid Electric Tractor for Agricultural Applications, *Energies* 2020, 13(12), 3055
2. Lagnelov O., Larsson G., Nilsson D., Larsolle A., Hansson PA., 2020, Performance comparison of charging systems for autonomous electric field tractors using dynamic simulation, *BIOSYSTEMS ENGINEERING*, Volume: 194 Pages: 121-137
3. Mengnan, L., Bing, H., Liyou, X. et al. 2020. CAN bus network design of bifurcated power electric tractor. *Peer-to-Peer Netw. Appl.* .
4. Troncon D., Alberti L., 2020, Case of Study of the Electrification of a Tractor: Electric Motor Performance Requirements and Design, *ENERGIES*, Volume: 13 Article Number: 2197
5. Xiaofei Z., 2017. Design Theory and Performance Analysis of Electric Tractor Drive System , *International Journal of Engineering Research & Technology*, Vol. 6 Issue 10, October - 2017
6. <https://www.electrincarpartscompany.co/>
7. <https://www.wolongelectric.com/product/prolist/55/102.html>
8. <https://www.greencarcongress.com/2014/10/20141017-siemens.html>
9. <https://evsource.com/products/ac-20-motor>
10. <http://www.servovision.com/Battery/Battery%20LithiumFerrumPhosphate%20LiFePo4%20cell%20aluminium.html>
11. <https://insideevs.com/news/335611/panasonic-increases-automotive-lithium-ion-battery-production-in-japan/>
12. <https://shop.gwl.eu/Battery-Management/BMS123-Smart/123-Smart-BMS-Complete-Set-4-cells-with-Bluetooth-4-0.html>
13. <https://www.orionbms.com/products/orion-bms-standard/>
14. [https://www.st.com/content/st\\_com/en/products/solutions-reference-designs/power-energy-management-solutions/automotive-power-management/sl-prapm07001v1.html#2](https://www.st.com/content/st_com/en/products/solutions-reference-designs/power-energy-management-solutions/automotive-power-management/sl-prapm07001v1.html#2)
15. <https://www.ti.com/solution/battery-management-system-bms?keyMatch=BMS&tisearch=Search-EN-everything>
16. <https://emusbms.com/product/g1-bms-control-unit>
17. <https://www.st.com/en/applications/electro-mobility/automotive-battery-management-system-bms.html>
18. <https://www.zeva.com.au/index.php?product=121>
19. <https://eveurope.eu/en/product/sevcon-size-6-gen4-ac-max-48v-550-amo/>
20. <https://eveurope.eu/en/product/curtis-1239e-7621-ac-controller-96vdc-650-amp-isolated/>
21. <https://www.thunderstruck-ev.com/tsm-96v-dc-dc.html>
22. <https://kellycontroller.com/shop/hwz/>
23. <https://www.distrelec.ro/ro/dc-dc-converter-72-144v-48v-01kw-mean-well-sd-1000h-48/p/16926103>
24. <https://evchargers.shop/en/product/tc-charger-hk-j-440-10-3-3-kw-lithium-battery-charger-can-steer-2/>

25. <https://evshop.fr/en/chargers/225-tc-charger-66kw-can-96v-1899v-80a.html>
26. [https://www.plugincars.com/clipper-creek-introduces-smaller-cheaper-more-portable-240-volt-charging-unit-128335.html?utm\\_source=feedburner&utm\\_medium=feed&utm\\_campaign=Feed%3A+PluginCars+%28PluginCars.com+RSS+Feed%29](https://www.plugincars.com/clipper-creek-introduces-smaller-cheaper-more-portable-240-volt-charging-unit-128335.html?utm_source=feedburner&utm_medium=feed&utm_campaign=Feed%3A+PluginCars+%28PluginCars.com+RSS+Feed%29)